

This drawing is exclusive property of Marelli. Without written permission from Marelli this drawing may not be reproduced or given to third parties or used to build the part. Marelli protect own rights as by law enacted.

PROJECT ID	CN9514	
PROJECT NAME	CN9514-ECU8x BASE	
FUNCTION/VER	Capri ECU	
PAGE NAME	00_Block Diagram	
PCBA VARIANT	REV. AA	PCBU REV. EBD000451 AA
Capri C928 High FEH0007934		SCHEMATIC REV. 0000067448 AA
DESIGNER NAME	DATE	SAMPLE PAGE OF
MENG ZHANG (F73963d)	Tuesday, April 16, 2024	B0 1 16

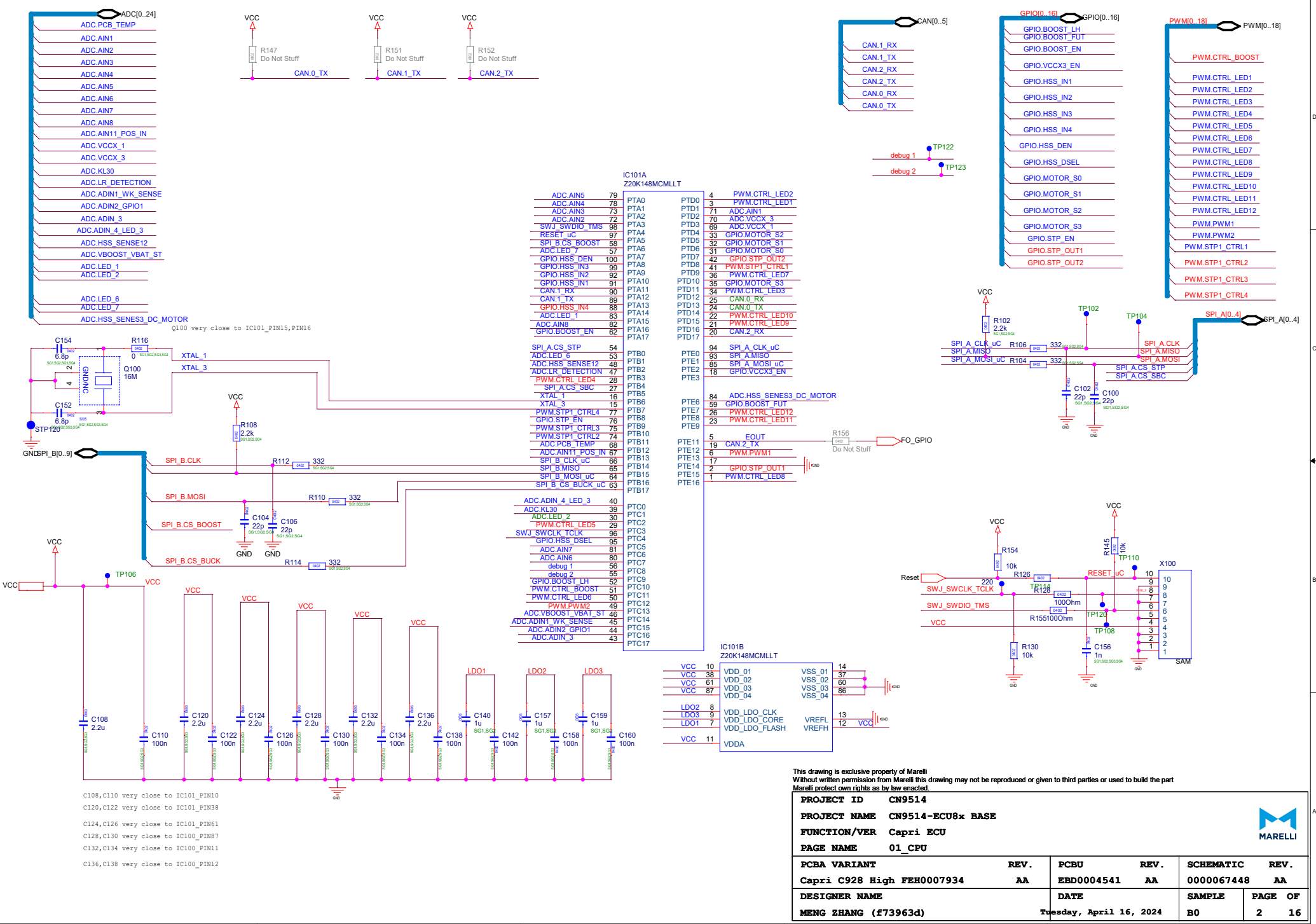

This drawing is exclusive property of Marelli. Without written permission from Marelli this drawing may not be reproduced or given to third parties or used to build the part. Marelli protect own rights as by law enacted.

PROJECT ID CN9514					
PROJECT NAME CN9514-ECU8x BASE					
FUNCTION/VER Capri ECU					
PAGE NAME 01_CPU					
PCBA VARIANT	REV.	PCBU	REV.	SCHEMATIC	REV.
Capri C928 High FEH0007934	AA	EBD0004541	AA	0000067448	AA
DESIGNER NAME			DATE		SAMPLE
MENG ZHANG (F73963d)			Tuesday, April 16, 2024		PAGE OF
			B0		2 16



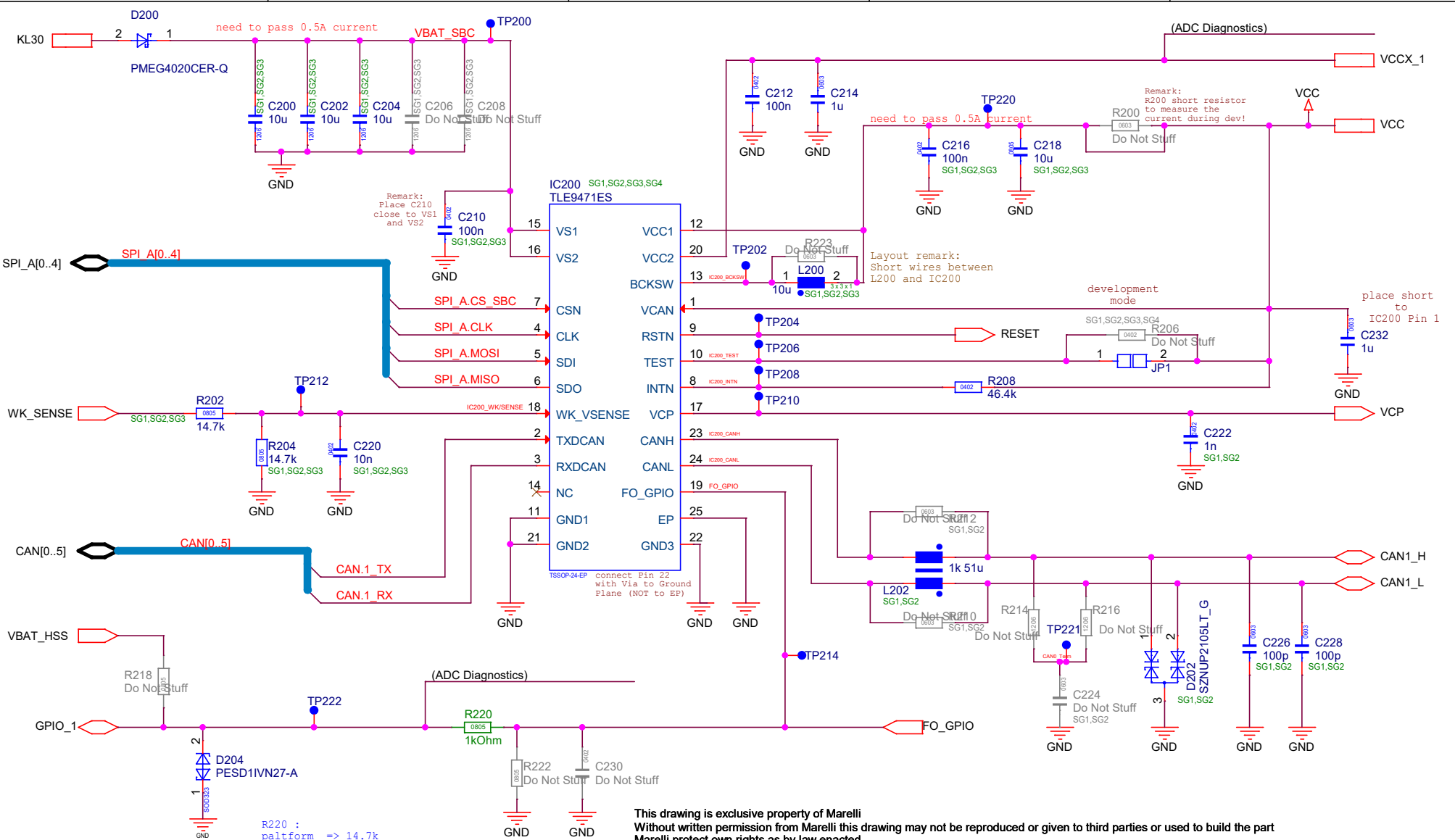

This drawing is exclusive property of Marelli
 Without written permission from Marelli this drawing may not be reproduced or given to third parties or used to build the part
 Marelli protect own rights as by law enacted.

PROJECT ID CN9514		PCBA VARIANT		REV.	PCBU	REV.	SCHEMATIC	REV.
PROJECT NAME CN9514-ECU8x BASE		Capri C928 High FEH0007934		AA	EBD0004541	AA	0000067448	AA
FUNCTION/VER Capri ECU		DESIGNER NAME		DATE		SAMPLE		PAGE OF
PAGE NAME 02_SBC		MENG ZHANG (f73963d)		Tuesday, April 16, 2024		B0		3 16



when use TLE9461 need to place R223

R220 :
platform => 14.7k
C928 => 1K

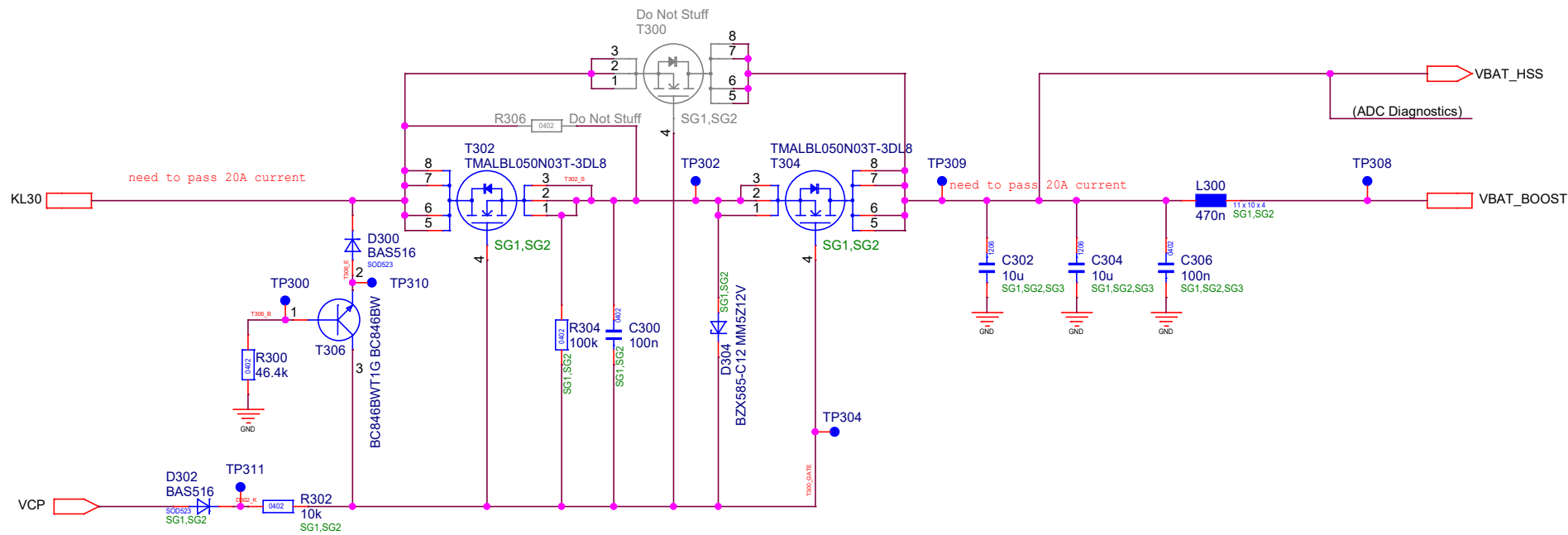

This drawing is exclusive property of Marelli
 Without written permission from Marelli this drawing may not be reproduced or given to third parties or used to build the part
 Marelli protect own rights as by law enacted.

PROJECT ID CN9514		PROJECT NAME CN9514-ECU8x BASE		FUNCTION/VER Capri ECU		PAGE NAME 03_Power Input					
PCBA VARIANT	Capri C928 High FEH0007934	REV.	AA	PCBU	EBD0004541	REV.	AA			SCHEMATIC	0000067448
DESIGNER NAME	MENG ZHANG (f73963d)			DATE	Tuesday, April 16, 2024			SAMPLE	B0	PAGE OF	4 16

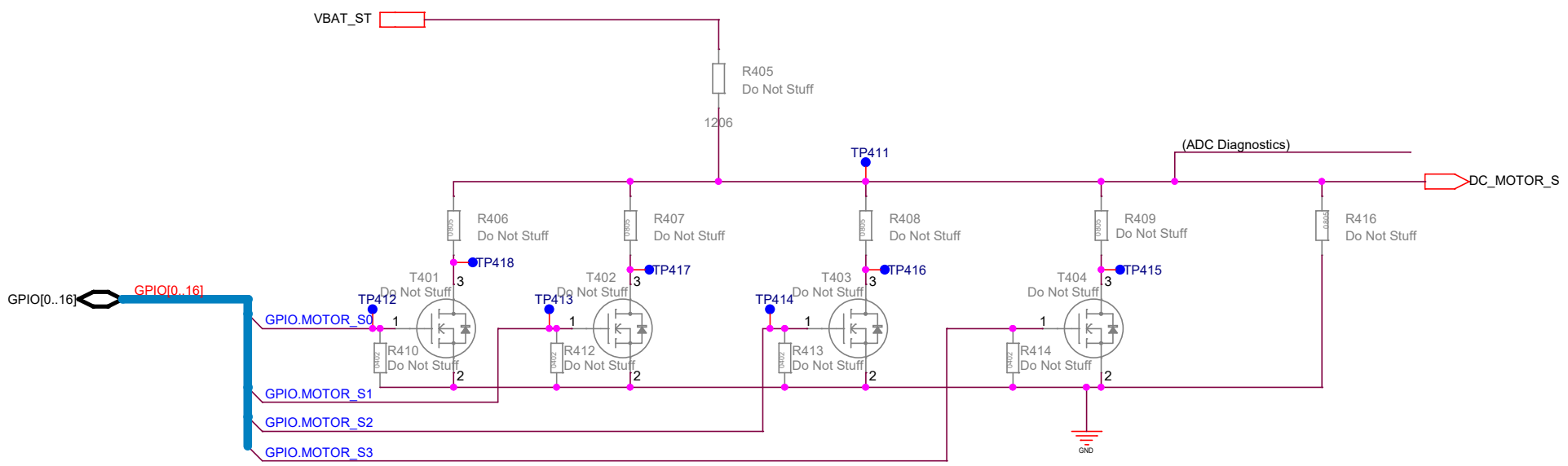

This drawing is exclusive property of Marelli
 Without written permission from Marelli this drawing may not be reproduced or given to third parties or used to build the part
 Marelli protect own rights as by law enacted.

PROJECT ID CN9514		PROJECT NAME CN9514-ECU8x BASE			
FUNCTION/VER Capri ECU		PAGE NAME 04_DC motor			
PCBA VARIANT	REV.	PCBU	REV.	SCHEMATIC	REV.
CEIDE926NH High FEH0007934	AA	EBD0004541	AA	0000067448	AA
DESIGNER NAME		DATE		SAMPLE	PAGE OF
MENG ZHANG (f73963d)		Tuesday, April 16, 2024		B0	5 16

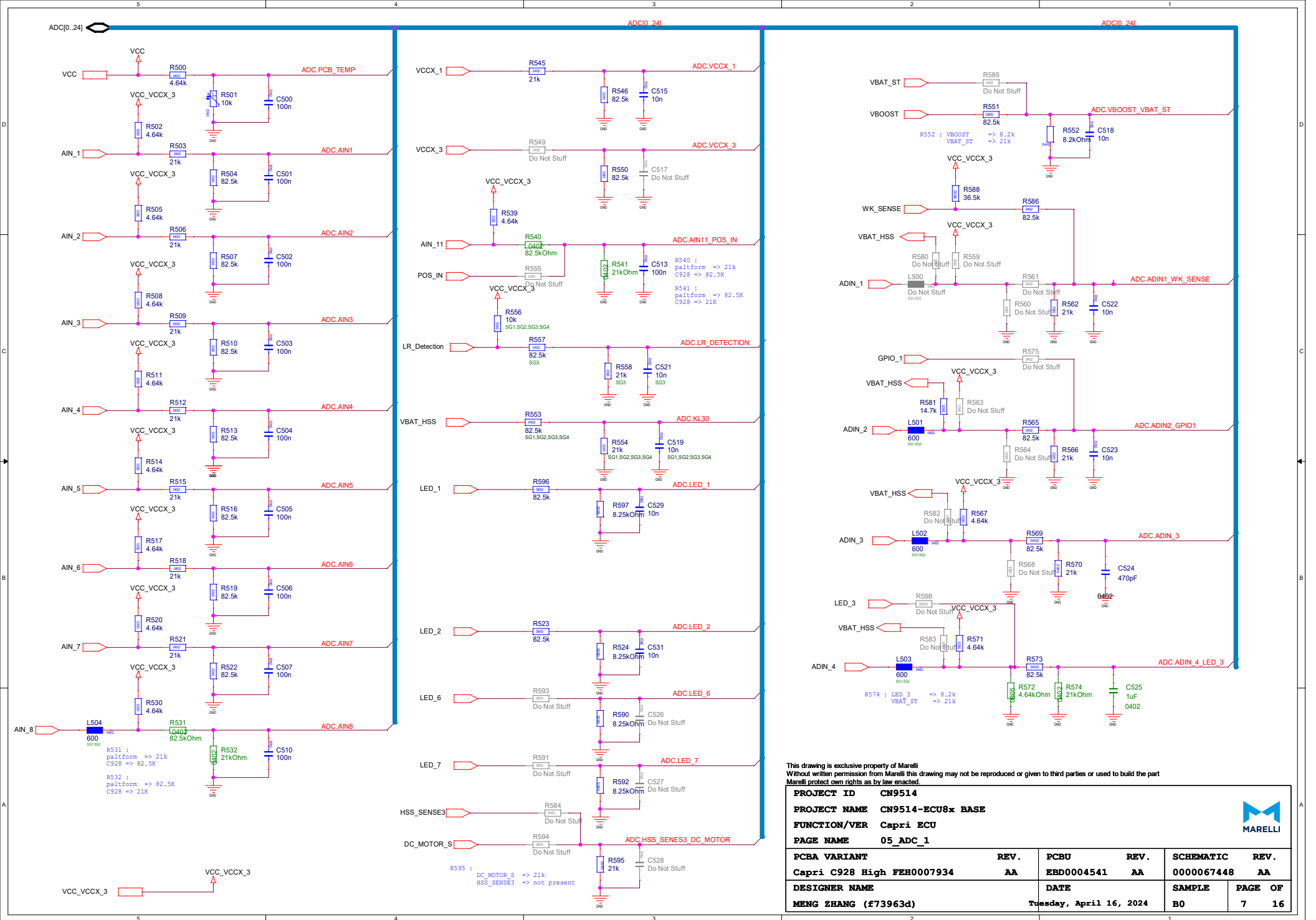

This drawing is exclusive property of Marelli
 Without written permission from Marelli this drawing may not be reproduced or given to third parties or used to build the part
 Marelli protect own rights as by law enacted.

PROJECT ID CN9514

PROJECT NAME CN9514-ECUx BASE

FUNCTION/VER Capri ECU

PAGE NAME 05_ADC_1

PCBA VARIANT	REV.	PCBU	REV.	SCHEMATIC	REV.
Capri C928 High FEH0007934	AA	EBD0004541	AA	0000067448	AA
DESIGNER NAME	DATE		SAMPLE	PAGE OF	
MENG ZHANG (F73963d)	Tuesday, April 16, 2024		B0	7	16



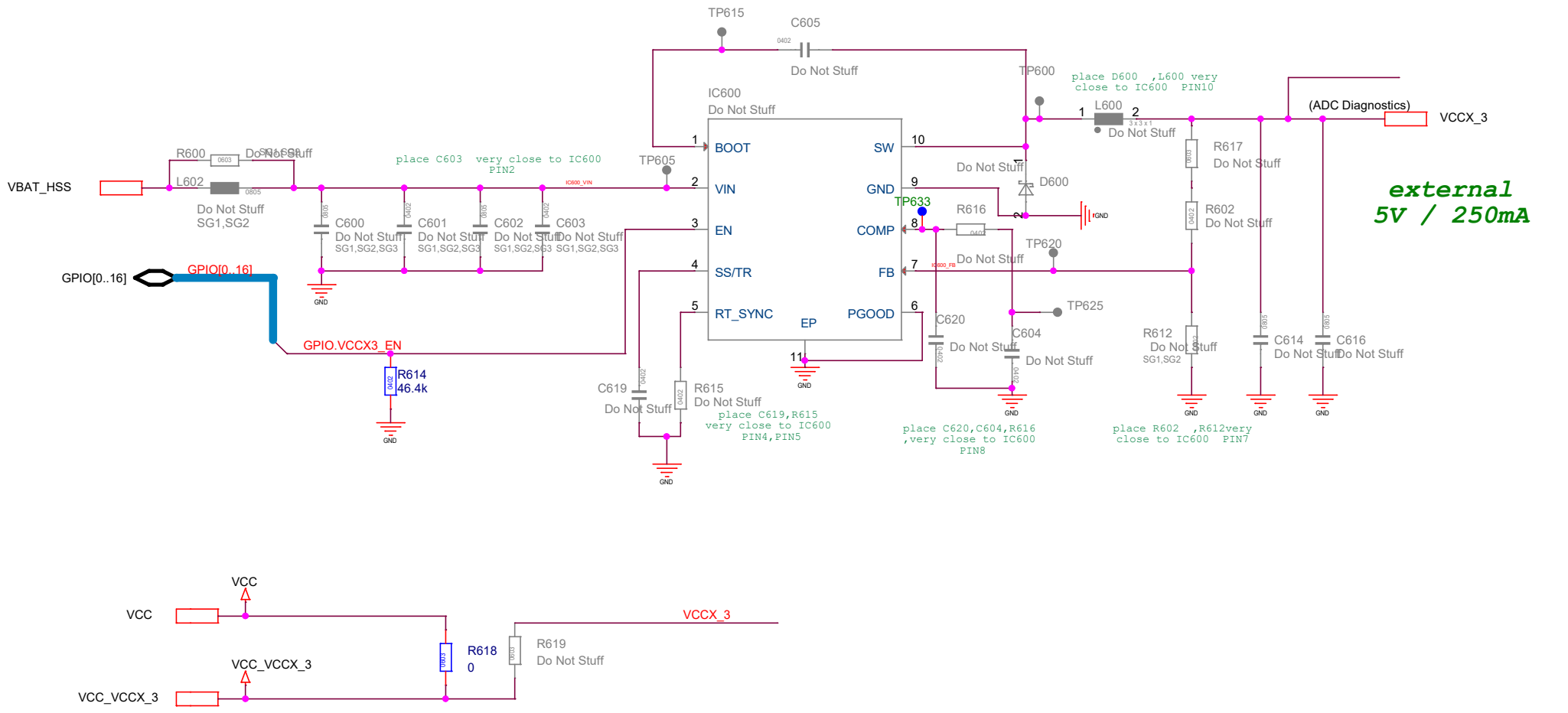

This drawing is exclusive property of Marelli
 Without written permission from Marelli this drawing may not be reproduced or given to third parties or used to build the part
 Marelli protect own rights as by law enacted.

PROJECT ID CN9514		PROJECT NAME CN9514-ECU8x BASE		FUNCTION/VER Capri ECU		PAGE NAME 06_VCCX_EXT					
PCBA VARIANT	Capri C928 High FEH0007934	REV.	AA	PCBU	EBD0004541	REV.	AA			SCHEMATIC	0000067448
DESIGNER NAME	MENG ZHANG (f73963d)			DATE	Tuesday, April 16, 2024			SAMPLE	B0	PAGE OF	8 16

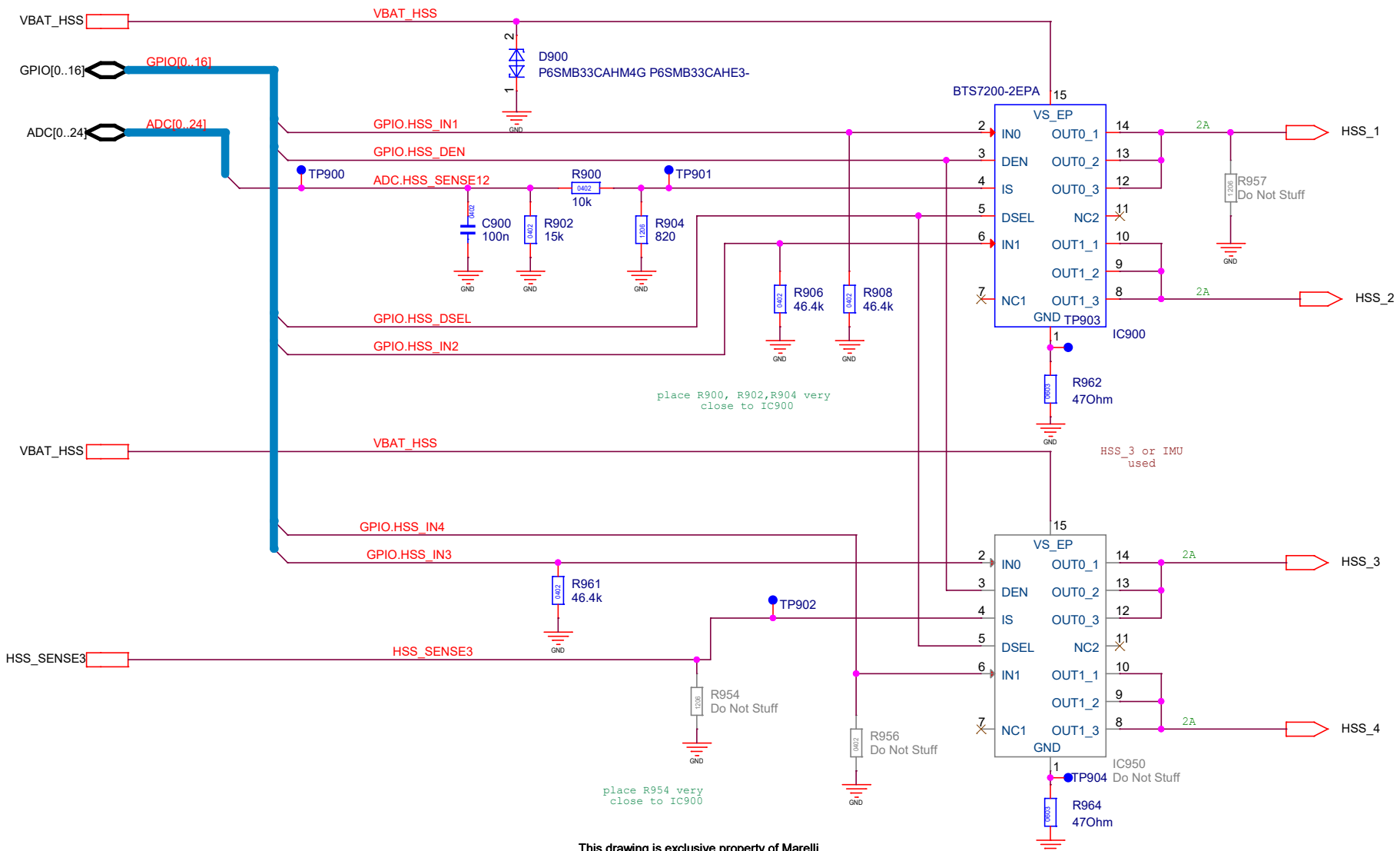

This drawing is exclusive property of Marelli
 Without written permission from Marelli this drawing may not be reproduced or given to third parties or used to build the part
 Marelli protect own rights as by law enacted.

PROJECT ID CN9514					
PROJECT NAME CN9514-ECU8x BASE					
FUNCTION/VER Capri ECU					
PAGE NAME 09_HSS					
PCBA VARIANT		REV.	PCBU		REV.
Capri C928 High FEH0007934		AA	EBD0004541		AA
DESIGNER NAME			DATE		SAMPLE
MENG ZHANG (f73963d)			Tuesday, April 16, 2024		PAGE OF
			B0		10 16



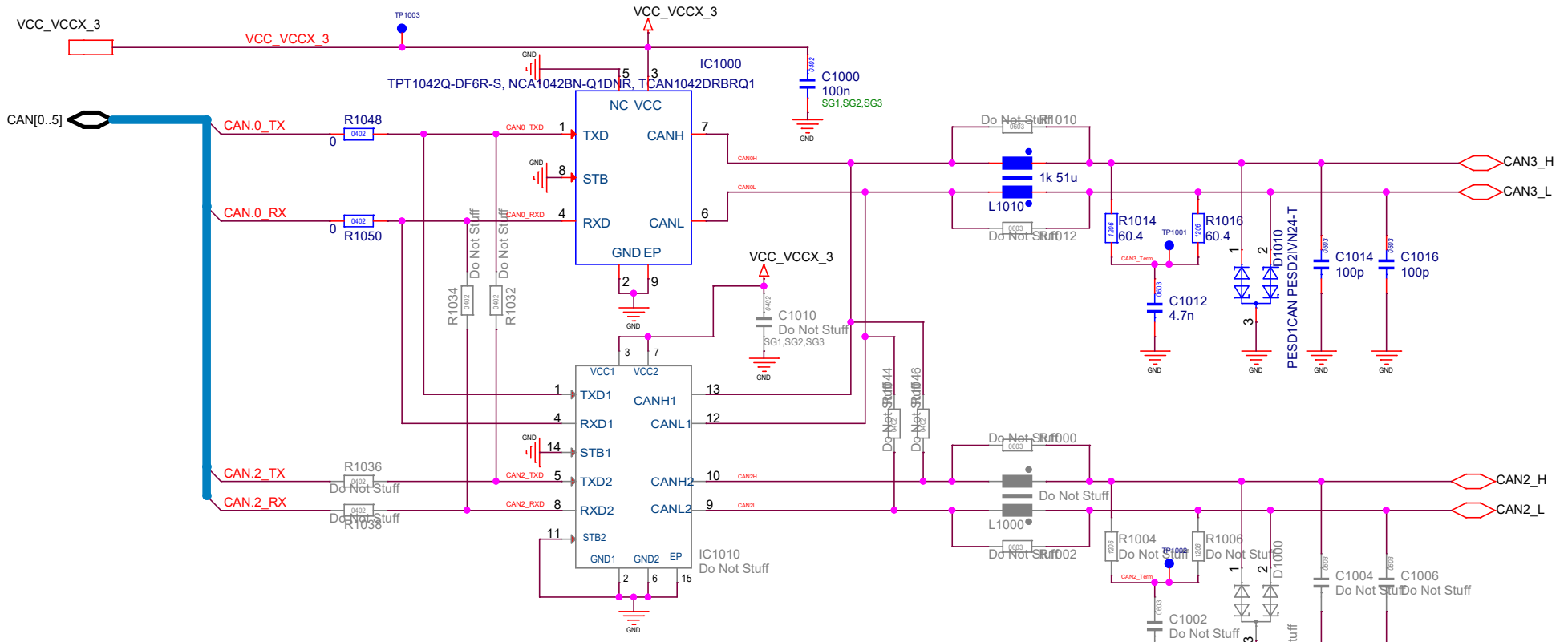

change IC1000 take care pin NC
 CAN0 can use UARTCAN0 and CAN0

This drawing is exclusive property of Marelli
 Without written permission from Marelli this drawing may not be reproduced or given to third parties or used to build the part
 Marelli protect own rights as by law enacted.

PROJECT ID CN9514		PROJECT NAME CN9514-ECU8x BASE		FUNCTION/VER Capri ECU		PAGE NAME 100_CAN_LIN				
PCBA VARIANT	Capri C928 High FEH0007934	REV.	AA	PCBU	EBD0004541	REV.	AA			SCHEMATIC
DESIGNER NAME	MENG ZHANG (f73963d)			DATE	Tuesday, April 16, 2024		SAMPLE	B0	PAGE OF	11 16

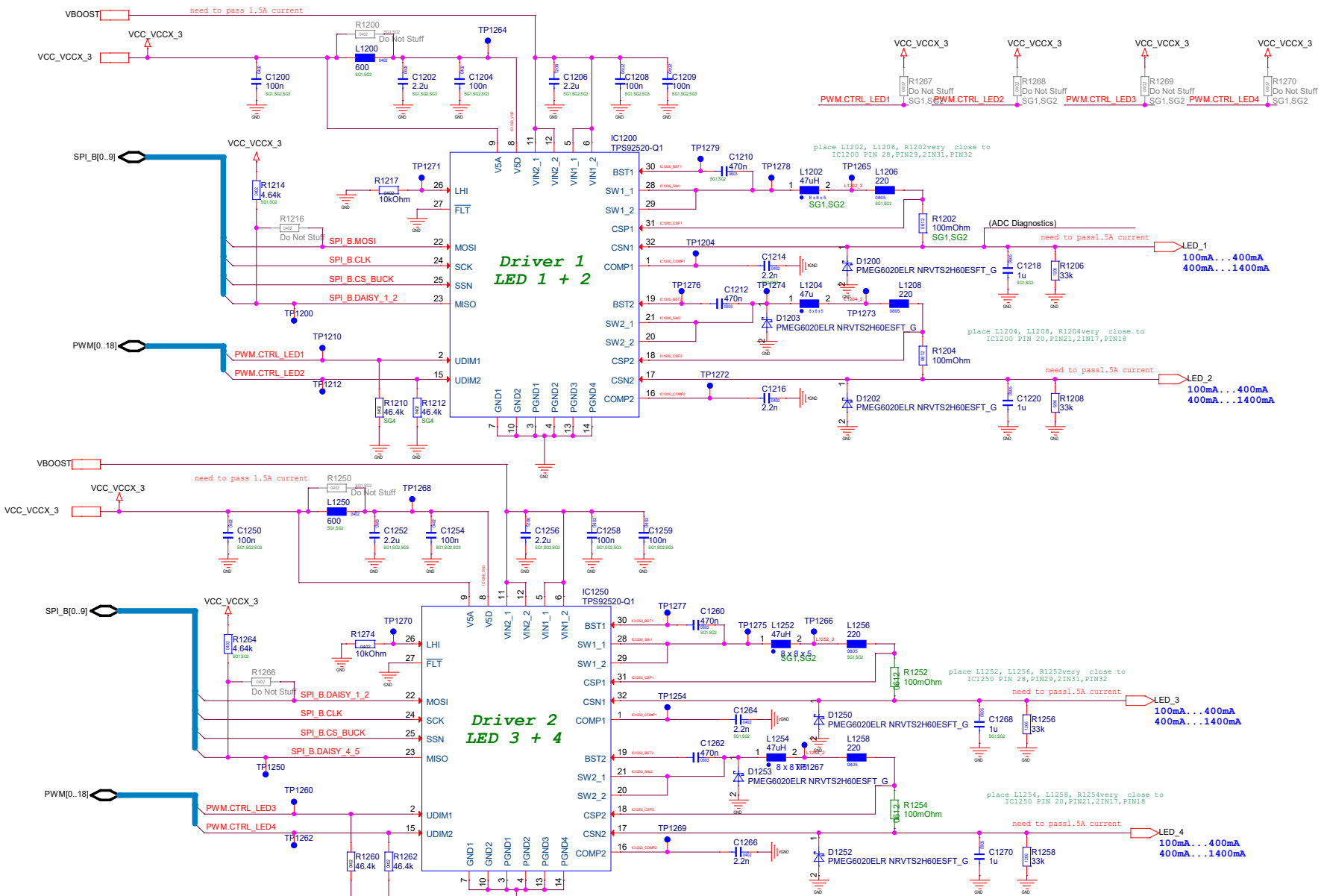

Driver 1
LED 1 + 2

Driver 2
LED 3 + 4

This drawing is exclusive property of Marelli
Without written permission from Marelli this drawing may not be reproduced or given to third parties or used to build the part
Marelli protect own rights as by law enacted.

PROJECT ID CN9514			
PROJECT NAME CN9514-ECU8x BASE			
FUNCTION/VER Capri ECU			
PAGE NAME 120_BUCK_1_2_3_4			
PCBA VARIANT	REV.	PCBU	REV.
Capri C928 High FEH0007934	AA	EBD0004541	AA
DESIGNER NAME	DATE	SAMPLE	PAGE OF
MENG ZHANG (E73963d)	Tuesday, April 16, 2024	B0	12 16

Shunt:
low power to 400mA = 150mOhm(1466001853)
high power to 1400mA = 100mOhm(1466001840)
coil:
low power to 400mA = 100uH(1466000628)
high power to 1400mA = 47uH (1466000627)

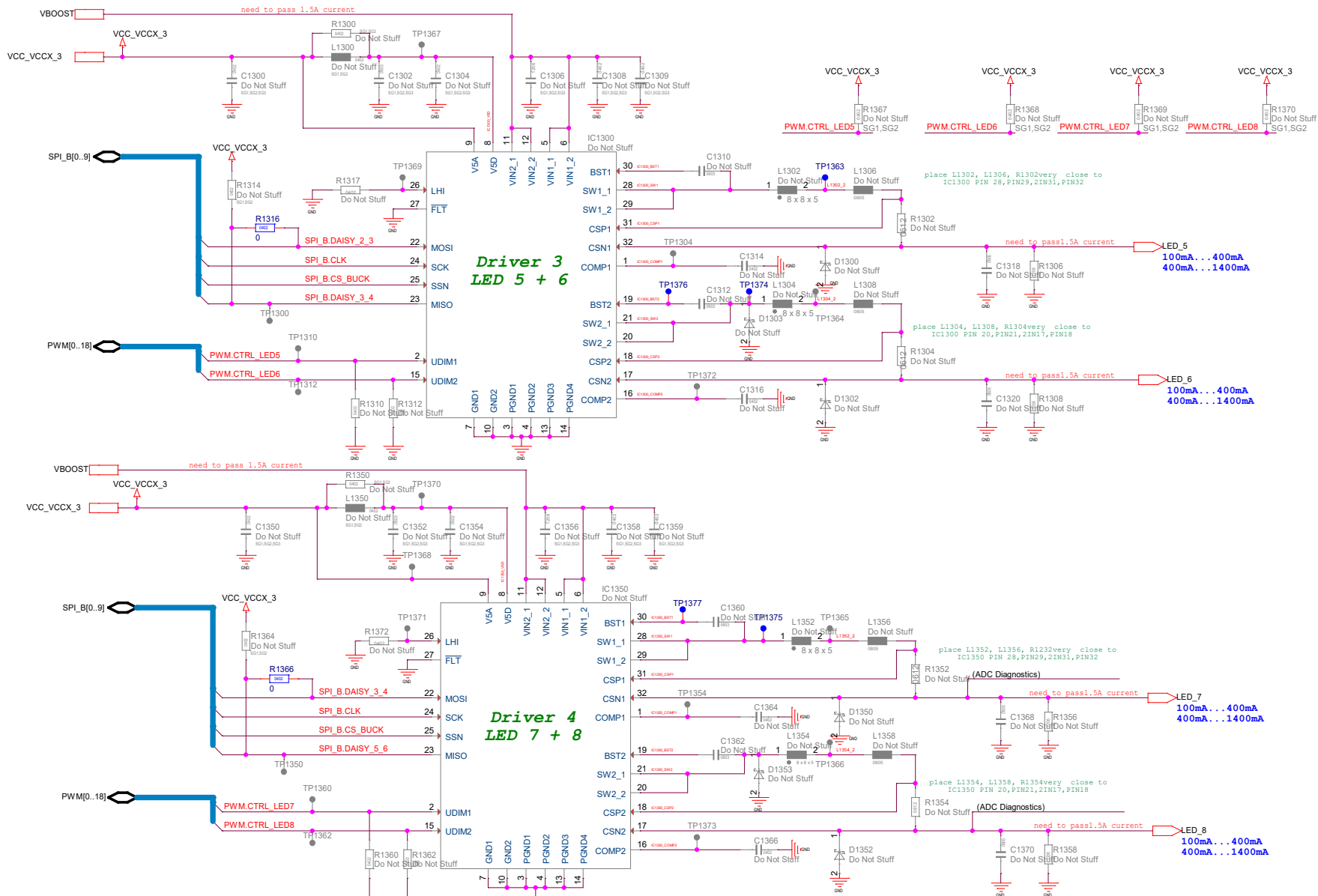

Driver 3
LED 5 + 6

Driver 4
LED 7 + 8

This drawing is exclusive property of Marell
Without written permission from Marell this drawing may not be reproduced or given to third parties or used to build the part
Marell protect own rights as by law enacted.

PROJECT ID CN9514		REV.		PCBU		REV.		SCHEMATIC		REV.	
PROJECT NAME CN9514-ECU8x BASE		AA		EBD0004541		AA		0000067448		AA	
FUNCTION/VER Capri ECU											
PAGE NAME 130_BUCK_5_6_7_8											
PCBA VARIANT		REV.		PCBU		REV.		SCHEMATIC		REV.	
Capri C928 High FEH0007934		AA		EBD0004541		AA		0000067448		AA	
DESIGNER NAME		DATE		SAMPLE		PAGE OF					
MENG ZHANG (F73963d)		Tuesday, April 16, 2024		B0		13		16			



Shunt:
low power to 400mA = 150mOhm(1466001853)
high power to 1400mA = 100mOhm(1466001840)
coil:
low power to 400mA = 100uH(1466000628)
high power to 1400mA = 47uH (1466000627)

place L1252, L1256, R1252very close to
IC1250 PIN 28, PIN29, 2IN31, PIN32

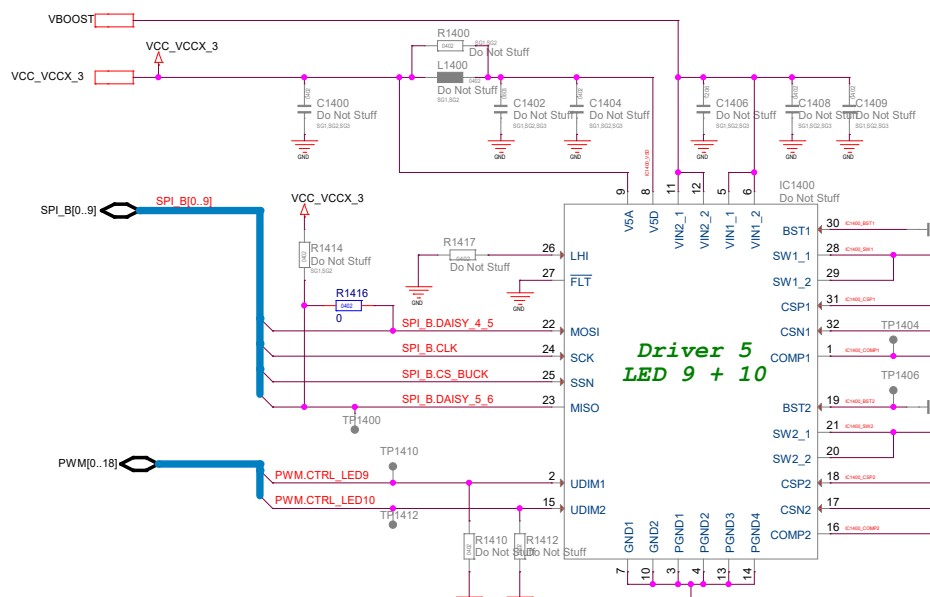

**Driver 5
LED 9 + 10**

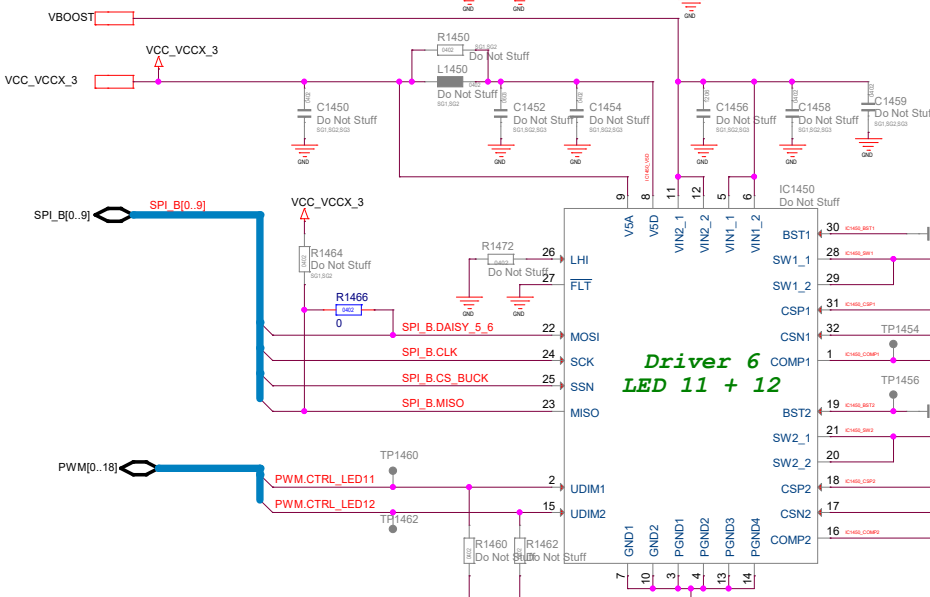
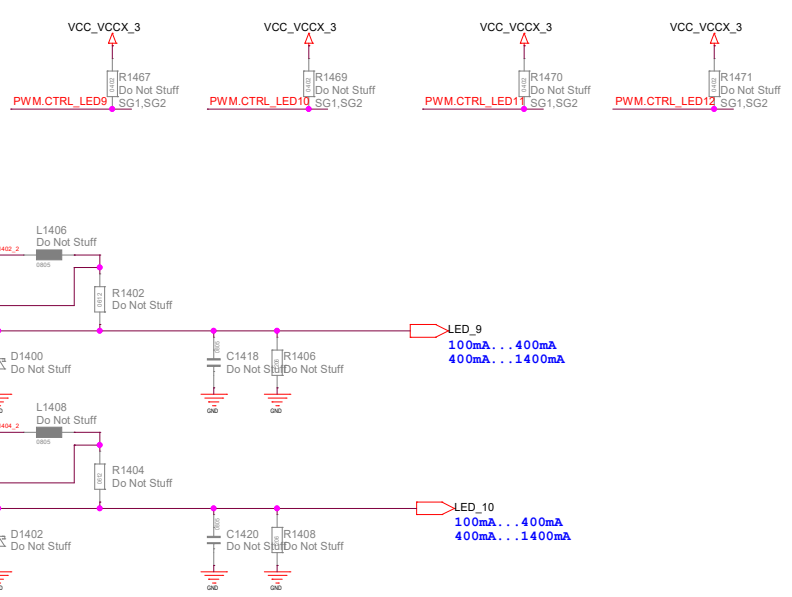

**Driver 6
LED 11 + 12**

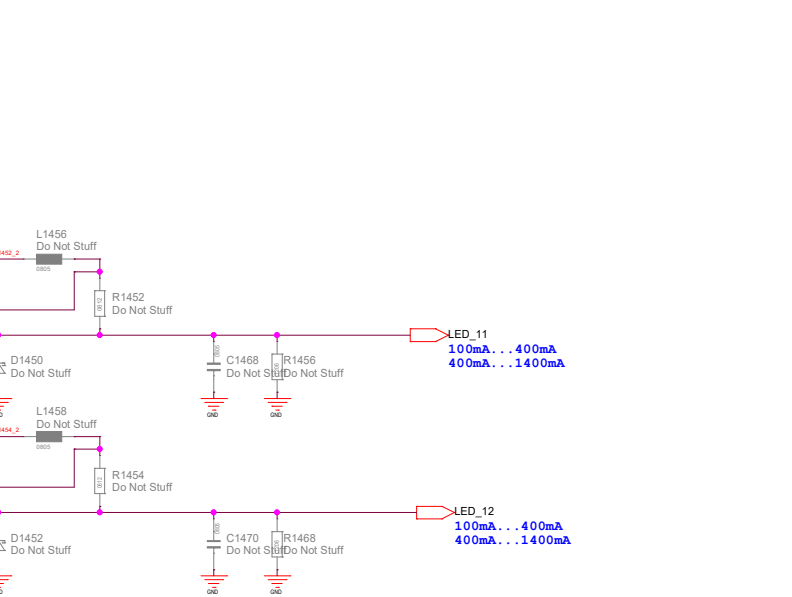

This drawing is exclusive property of Marelli. Without written permission from Marelli this drawing may not be reproduced or given to third parties or used to build the part. Marelli protect own rights as by law enacted.

PROJECT ID CN9514		PCBU		REV.		SCHEMATIC		REV.	
PROJECT NAME CN9514-ECU8x BASE		Capri		AA		EBO0004541		AA	
FUNCTION/VER Capri ECU		Capri C928 High FEH0007934		AA		EBO0004541		AA	
PAGE NAME 140_BUCK_9_10_11_12		DESIGNER NAME		DATE		SAMPLE		PAGE OF	
		MENG ZHANG (F73963d)		Tuesday, April 16, 2024		B0		14 16	



Shunt:
 low power to 400mA = 150mOhm(1466001853)
 high power to 1400mA = 100mOhm(1466001840)
 coil:
 low power to 400mA = 100uH(1466000628)
 high power to 1400mA = 47uH (1466000627)

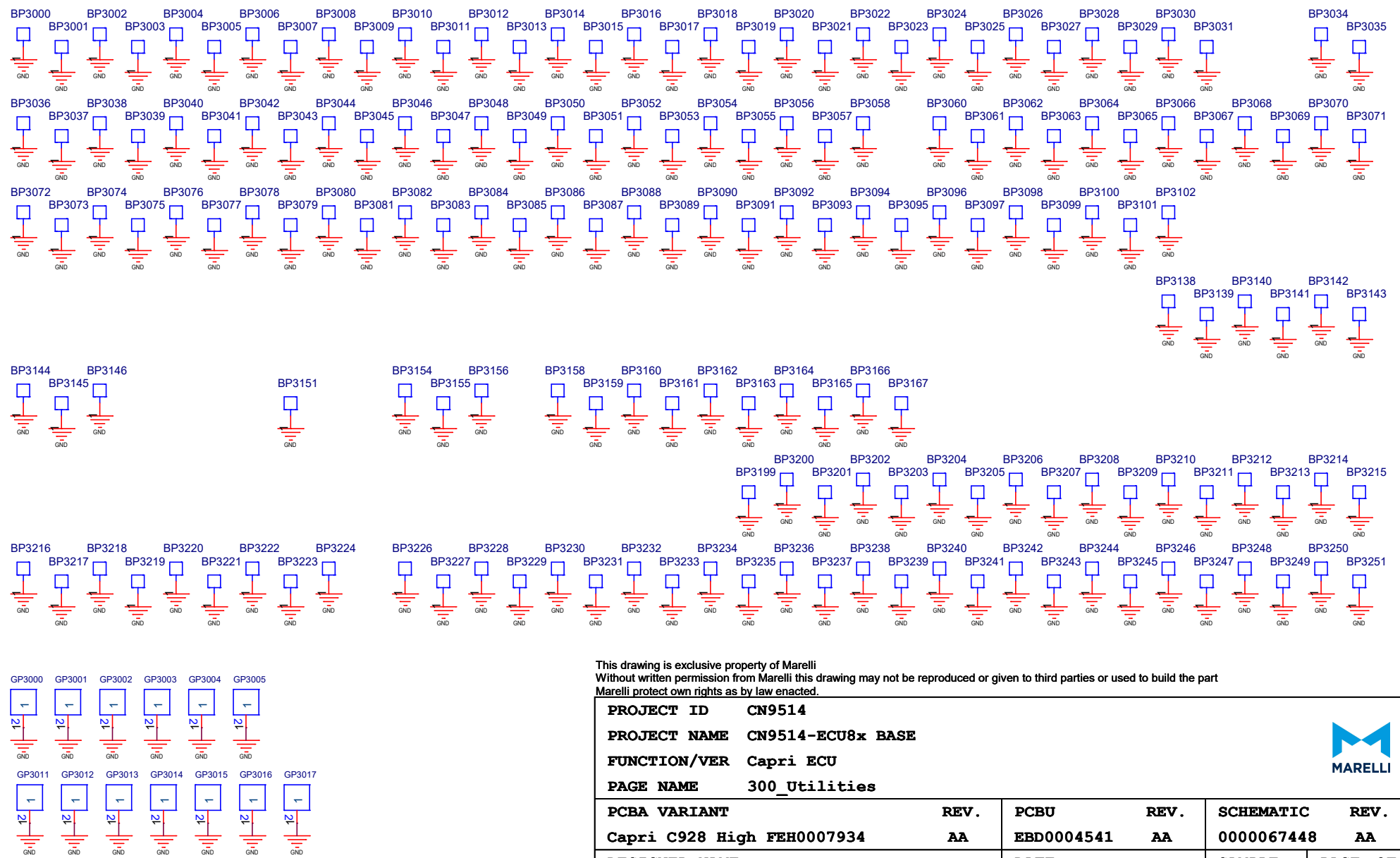
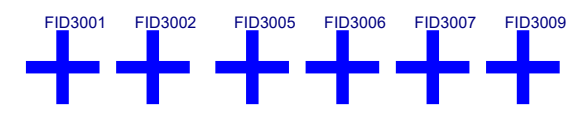

This drawing is exclusive property of Marelli
 Without written permission from Marelli this drawing may not be reproduced or given to third parties or used to build the part
 Marelli protect own rights as by law enacted.

PROJECT ID CN9514		PROJECT NAME CN9514-ECU8x BASE			
FUNCTION/VER Capri ECU		PAGE NAME 300_Utilities			
PCBA VARIANT Capri C928 High FEH0007934	REV. AA	PCBU EBD0004541	REV. AA	SCHEMATIC 0000067448	REV. AA
DESIGNER NAME MENG ZHANG (f73963d)		DATE Tuesday, April 16, 2024		SAMPLE B0	PAGE OF 15 16

